



# V1000

## VENTILATING AIR TREATMENT UNIT

### A system without compromises

**UVpro V1000** ventilating air treatment units are ideal for subsequent installation and reliable treatment of any areas in the industrial food production up to 800 m<sup>3</sup>. The adjustable ventilation system allows a regulation and significant increase in the UVC dose, so that mould spores are killed in a single run. Equipped with a corrosion-resistant reflector.

---

**Adjustable ventilation system**

---

**Easy installation, also subsequently**

---

**For production, ripening and storage rooms**

---



#### SPECIFICATIONS

Type	UVpro V1000
In conformity with requirements	EMC, CE, IP54
Material	stainless steel: WN 1.4301 and WN 1.4305
Operating temperature [°C]	-10 to +40
Input power [W]	296
Current flow [mA]	1200
Suitable UVpro lamp	UVpro K(T)40-4 (6x 41 W)
Total UVC output [ $W_{253,7\text{ nm}}$ ]	84
Air volume [ $m^3/h$ ]	250 - 800 (adjustable)
Noise emission [dB]	30 to 51 (adjustable)
Mount	2 eyelets for chain attachment
Size (L x Ø) [mm]	1091 x 314
Weight [kg]	29.5
Lamp replacement interval [h]	12,000 (75 % <sup>+5%</sup> output performance)
Life expectancy electronics	> 10 years
Supply voltage [ $V_{AC}$ ]	220-240 (50-60 Hz)
Power cable length [m]	5 (length customisable)

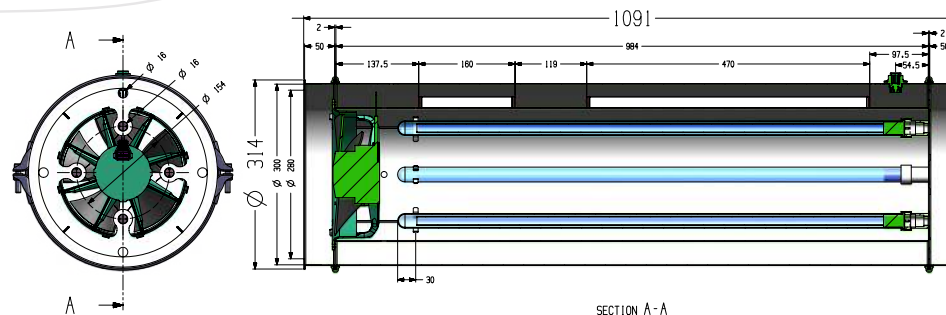

#### Application Optimised UV for



Food & Beverage  
Industrial UV



Healthcare  
Industrial UV



Pharmaceuticals  
Industrial UV



#### Canada

+1 980.256.5700  
americas@nuvonicuv.com

#### Mexico

+1 980.256.5700  
americas@nuvonicuv.com

#### China

+86 21 61679599  
apac@nuvonicuv.com

#### United Kingdom

+44 1753 515300  
emea@nuvonicuv.com

#### Germany

+49 (0)2268 908300  
germany@nuvonicuv.com

#### USA

+1 980 256 5700  
americas@nuvonicuv.com

#### Malaysia

+60 16 440 8834  
sea@nuvonicuv.com